

INSTALLATION & OPERATING MANUAL



STREBEL SU CP-1 PRESSURISATION UNIT

Strebel Ltd
1f Albany Park Industrial Estate
Frimley Road
Camberley
Surrey, GU16 7PB
Tel.: 01276 685422 Fax: 01276 685405
E-mail: info@strebel.co.uk

Installation

Pressurisation units operate together with a suitably sized expansion vessel to maintain the ambient cold fill pressure and accommodate the changes in volume within the system when heated or chilled.

Pressure is controlled by the use of a switch set during commissioning to the correct value. A differential of 0.4 bars between on and off allows for minor fluctuation within the system.

The system should be flushed and tested for leaks before connecting the unit and the expansion vessel to prevent dirt or metal particles from entering.

The unit should not be used to fill the system only to achieve the required pressure. The incoming flow rate to the unit must be greater than the pump output.

- **Damage to the pump will occur if it is allowed to run dry.**
- **Do not introduce water treatment into the system via the unit**

Location and mounting

The unit must be installed undercover in a dry and ventilated area and must be protected from frost. Reasonable access should be allowed for maintenance.

Mark a suitable position on the wall using the template provided, mark and drill two holes and secure the bracket to the wall. Hang the unit onto the bracket.

For additional security additional fixing can be used, taking care not to damage any internal components.

Mechanical connections

All water connections and pipe-work must comply with current legislation and local authority requirements

Connect the cold mains supply to the inlet with a suitable fitting taking care not to allow dirt or jointing material to enter the float valve. An isolating valve should be installed for future maintenance.

Connect the overflow so that it can discharge to a suitable noticeable position.

Connect the outlet of the unit to the return side of the system and the suction side of the pump. An anti gravity loop should be installed with an auto air vent between the pressurisation unit and the expansion vessel. If the flow temperature exceeds 95°C an additional intermediate cooling vessel will be required (see diagram) to prevent damage to the diaphragm.

Fit a lock shield pattern valve and a drain off at the lowest point in the supply pipe to allow future maintenance to the pressurisation unit and expansion vessel.

Commissioning and setting

Check the cold water inlet supply has a flow greater than that of the pump (see data sheet). The unit is supplied with a number of inserts to be installed in the cold supply to achieve the correct flow output.

If the mains pressure exceeds 4bar fit the high-pressure restrictor.

Check that a suitable isolating valve's has been installed in the cold-water inlet and the system outlet.

Check that the unit is connected to the electrical supply via a fused isolator.

Set the pump pressure switch to the required cold fill pressure.

Before filling the system set the air cushion pressure in the expansion vessel while it is still cold and dry to that of the system cold fill pressure.

See system-sizing guide.

Filling the system

The system should be filled and tested for soundness before operating the unit.

Close the lock shield valve between the unit and the system and open the inlet valve to fill the break tank to the required level, check the float valve is operating correctly.

Prime the pump by opening the bleed screw on the pump head until water is visible, close the screw (if the pump fails because it has been run dry the warranty will be void).

Set the pump pressure switch to the required cold fill pressure, and turn on the pump with the system valve still closed, the pump should run for a few seconds until the pre set pressure is reached.

Check for leaks and then open the system lock shield valve and the pump should again start bringing the system to the correct pressure, the pump will then stop.

Check again for leaks, the system pressure will now be maintained to the correct level.

Electrical requirements

The unit must be connected to a fused isolator rated to suit the unit and must comply with I.E.E. regulations.

THE APPLIACE MUST BE EARTHED

Design guide

The following is a guide only to sizing sealed system expansion vessels and pressurisation units.

When water is heated it expands, if a sealed system is to be used provision is required to take up that expansion,

To size an expansion vessel the following information is required

- The system water content
- The maximum operating temperature
- The initial cold fill pressure
- The maximum allowable final working pressure

If the system volume is not known the following rule of thumb guide can be used.

*Old systems with large pipe-work and high volume or column radiators.
12 litres per kW of boiler power*

*Modern systems with panel radiators and fan convector units
9 litres per kW of boiler power*

*Modern systems with under floor heating or thermal panel radiators
6 litres per kW of boiler power.*

If in doubt always use the higher figure.

Water expands by approximately 3% at 85°C therefore the expansion vessel must be sized to accept the additional volume, an example is given below.

A modern heating system total output 140kw with panel radiators

140 x 9 = 1260litres

1260 litres at 3% expansion = 37.8 litres expansion water.

The expansion acceptance of the vessel is 33-40% therefore vessel size required 94.5 litres minimum. The nearest vessel will be 105litres.

The cold fill pressure is equal to the highest point of the system + 0.2bar, in a 3 story building of 7.8 metres height the cold fill pressure is 0.98bar.

With many modern boilers a minimum cold fill pressure of 1.0bar or more is required.

To find the final working pressure we apply Charles & Boyles Law $P_1 \times \frac{V_1}{V_2} = \frac{T_1}{T_2}$

P1 = cold fill pressure

V1 = cold volume of expansion vessel V2 = hot volume of expansion vessel

T1 = cold temperature absolute T2 = hot temperature absolute

From our example $0.98 \times \frac{105}{105-38} \times \frac{273 + 80}{273 + 15}$

0.98 x 1.56 x 1.23 = 1.88bar final working pressure.

Schematic arrangement pressurisation unit and expansion vessel

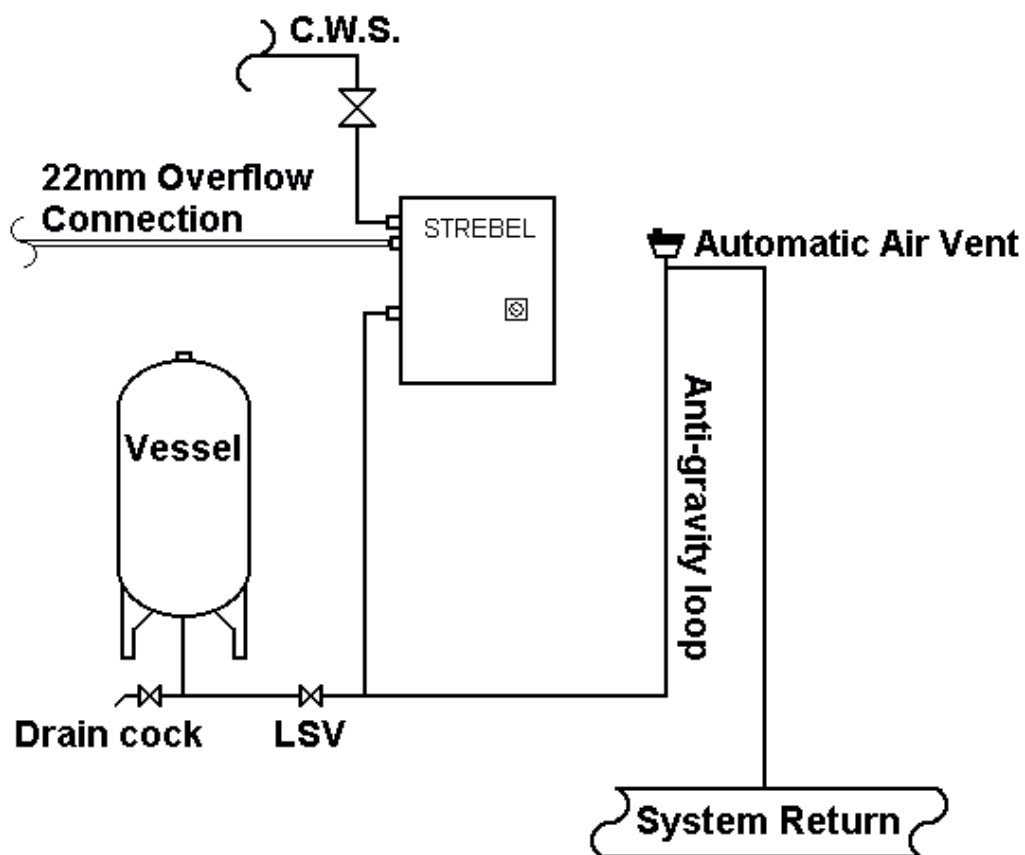

Wiring terminal details

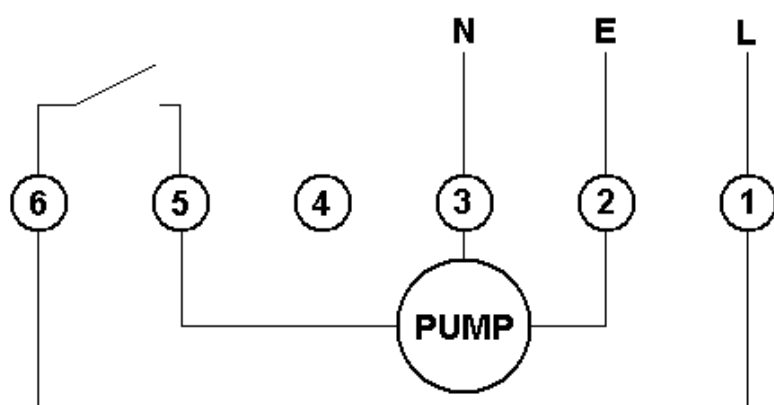

Maintenance

The following checks should be completed on an annual basis or if a problem occurs.

This should be done after the system has been shut down and is cold.

Isolate the electrical supply before opening the outer casing.

Isolate and drain the expansion vessel, check the air pressure with a standard tyre pressure gauge, adjust by adding or removing air until the required setting has been achieved.

Drain the water from the break tank and remove any dirt or sediment and check the operation of the float valve make sure the overflow is clear.

Check the operation of the pump and pressure switches, if a fault is found they must be replaced as there are no user serviceable parts.

Reset the switches to their original settings.

Refer to the commissioning instructions to put the unit back into operation.

Strebel SU CP-1 Single Pump Wall Hung Pressurisation Unit Data Sheet

General

Cabinet Overall Dimensions	345* (width) x 430 (height) x 140 (depth) *-Allow additional 35mm width for connections.	
Weight	13 kg (empty) 16 kg (full)	
Connections	Inlet	3/8" BSP (Male)
	Overflow	3/4" Plastic (Female)
	Outlet	1/2" BSP (Male)
	Mains	3-core cable (0.75mm) 1m flying lead via M13 cable gland
Operating Pressure Range	0.7 - 3.0 bar	
Maximum Flow Rate	6 litres/min	
Tank Capacity (actual)	2.6 litres	
Features	Pump control Pressure Switch Non-return valve 0 – 6 bar System pressure gauge Corrosion resistant brass/copper/plastic pipework	
Enclosure	Zintec steel, 0.9mm/1.2mm Powder coated – white Suitable for wall-mounting (bracket included)	

Pump Details

Maximum Pressure	3.4 bar (@ 0.1 l/min flow)
Electrical	230v 50/60Hz 2.8A run current 9A start current

Pressure Switch Details

Pressure Range	0.7 – 7 bar
Nominal Pressure Differential	0.4 bar
Electrical	SPDT / 15A / 230v AC

THE COMPANY RESERVES THE RIGHT TO CHANGE SPECIFICATIONS AND DIMENSIONS WITHOUT NOTICE

STREBEL LTD

1F Albany Park Industrial Estate
Frimley Road, Camberley, Surrey, GU16 7PB
Telephone: 01276 685422 Fax: 01276 685405
E-mail address: info@strebel.co.uk
Website: www.strebel.co.uk
